

Belt press **POWERPRESS 1500** is designed for pressing fruit, berry and vegetable mass. Fruit mass is placed on the belt which presses it against cylinders.

The obtained juice flows into integrated collection tank under the press. Then the pump transfers the juice from the press to a desired tank for further processing. The pressing process is continuous.

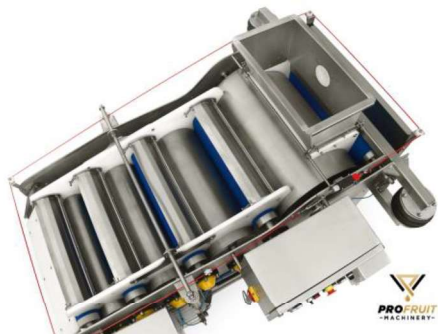

- The most evolutionary feature of our Belt press POWERPRESS line is that belt presses come with integrated pump and juice collection tank. This means you save money and do not need an additional juice collection tank and pump which otherwise would use much space and cause additional costs.
- The juice yield of apples using our belt press is ~75 %.
- There is a filtration sieve integrated into the juice collection tank. It filtrates the juice even during the pressing stage providing cleaner and purer product.
- The belt presses work automatically: when the mash inlet tank is full, all other machines, which come before belt press, turn off automatically. When the juice tank is full, the pump automatically pumps the juice into the tanks.
- The belt press includes a high-pressure washer, which continuously washes the belt of the machine. Our belt washing system is simple, does not contain any engines or reducers, so it prolongs the use time and saves service costs.
- After work, belt press should be manually washed with a



water stream. A full washing process takes around 15-20 minutes. Washing is simple and all the parts of the belt press are easily removable without any tools.

- Pneumatic lifting of the security cover of the press ensures easier access when cleaning.
- Belt tension is adjustable.
- The machine is made entirely of stainless steel and has adjustable feet.
- Easy to clean with no closed or inaccessible spaces, all parts are easy to assemble
- Different efficiency [POWERPRESS 400](#), [POWERPRESS 800](#), [POWERPRESS 1200](#)

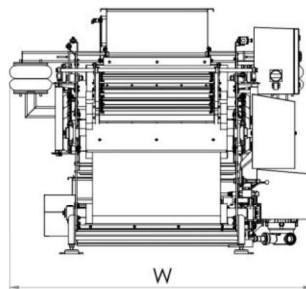
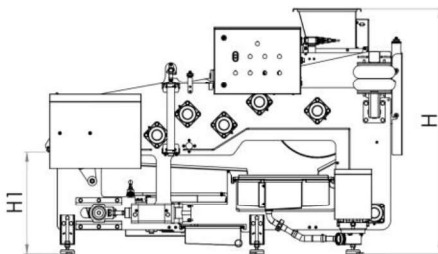

Output	kg/h	1500
L	mm	1950
W	mm	1655
H	mm	1350
H1	mm	570
T	mm	700
AxB	mm	315x550
Weight	kg	800
Supply source	kW	1.5
Supply voltage	V	3/N/PE - 400 V 50Hz

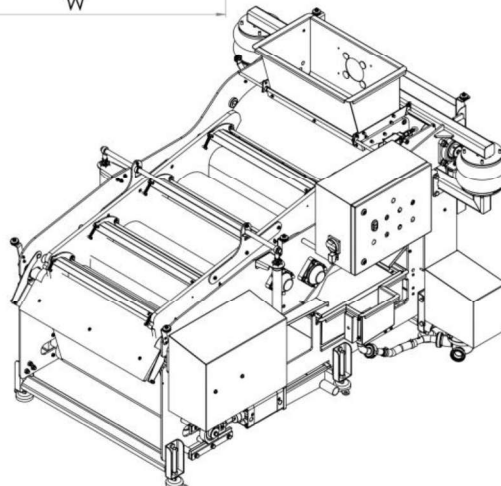
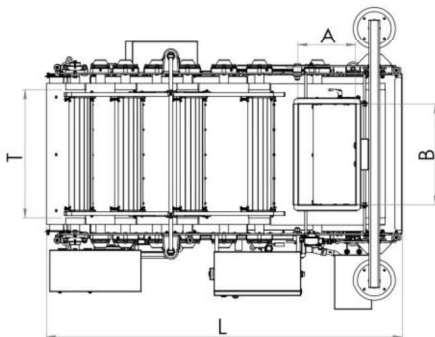

	Machine	Belt press
	Type	POWERPRESS 1500